

# Pliers

<b>Pliers</b>	Introduction	E.2
	VDE insulated combination pliers	E.3
	VDE insulated side-cutting pliers	E.4
	VDE insulated telephone pliers	E.5
	VDE insulated flat- and round-nose pliers	E.6
	VDE insulated special function pliers	E.7

# Pliers

Working on live systems calls for special safety procedures and special tools specially produced and tested for such applications.

Weidmüller can provide users with a complete range of pliers complying with national and international testing standards.

All Weidmüller pliers are produced and tested to DIN EN 60900.

Their ergonomic design fits snugly in the hand, resulting in a more natural, non-fatiguing hand position so you don't catch your fingers.

## E



**VDE insulated combination pliers**

**up to 1000 V (AC) and 1500 V (DC) protective insulation to IEC 900, DIN EN 60900**

- drop-forged from high-quality special tool steels
- safety handle with ergonomic and non-slip TPE VDE sleeve
- made from shockproof, heat-and cold-resistant, not readily flammable, cadmium-free TPE (thermoplastic elastomer)
- elastic grip zone and hard core
- polished surface
- nickel-chromium electrogalvanised coating protects against corrosion

**KBZ 160 – KBZ 180 – KBZ 200**

Combination pliers



**KBZI 200**

Heavy-duty combination pliers (telephone pliers)



**Combination pliers to DIN ISO 5746**

- with jaw opening (see sketch) foil and sheet up to a thickness of 2.5 mm can be gripped with the tip up to a thickness of 2.5 mm the gripping force pulls the workpiece towards the joint
- especially long cutter for ribbon and round cables
- for cutting soft and hard wire
- cutting edges inductively hardened to approx. 60 HRC

**Telegraph pliers (combination pliers) to DIN 5746**

- heavy-duty model for tough jobs
- extra-long cutter for ribbon and round cables
- for cutting soft and hard wire
- cutting edges inductively hardened to approx. 60 HRC

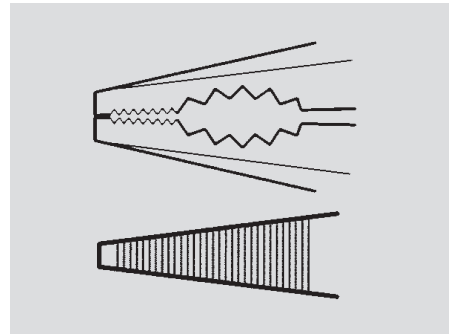
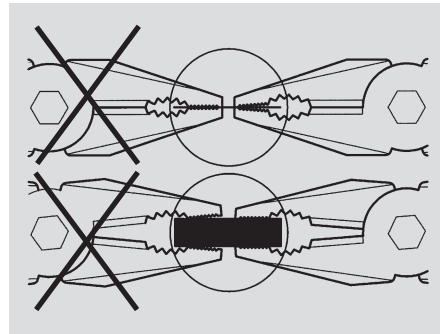

**Technical data**

Stripping	
Stripping diameter, max.	mm
Conductor cross-section, max..	mm <sup>2</sup>
Cutting performance	
Conductor diameter max. (H)	mm
Conductor diameter max. (MH)	mm
Conductor diameter max. (P)	mm
Tool data	
Cutter hardness	HRC
Total length tools	mm
Weight	g
Information	

	KBZ 160	KBZ 180	KBZ 200
Stripping diameter, max.			
Conductor cross-section, max..			
Cutting performance			
Conductor diameter max. (H)	1.8	2.5	2.5
Conductor diameter max. (MH)	2.5	2.8	3
Conductor diameter max. (P)			
Tool data			
Cutter hardness	60	60	60
Total length tools	160	180	200
Weight	230	290	362
<b>(MH)</b> medium-hard wire; <b>(H)</b> hard wire; <b>(P)</b> piano wire			

	KBZI 200
Stripping diameter, max.	
Conductor cross-section, max..	
Cutting performance	
Conductor diameter max. (H)	2.5
Conductor diameter max. (MH)	3
Conductor diameter max. (P)	
Tool data	
Cutter hardness	60
Total length tools	200
Weight	412
<b>(MH)</b> medium-hard wire; <b>(H)</b> hard wire; <b>(P)</b> piano wire	

**Ordering data**

Version
Information

Type	Qty.	Order No.
KBZ 160	1	9046280000
KBZ 180	1	9046290000
KBZ 200	1	9046300000
Information		

Type	Qty.	Order No.
KBZI 200	1	9046430000
Information		

**Accessories**

Information

Information

Information

## VDE insulated side-cutting pliers

### VDE insulated side-cutting pliers

#### up to 1000 V (AC) and 1500 V (DC) protective insulation to IEC 900, DIN EN 60900

- drop-forged from high-quality special tool steels
- safety handle with ergonomic and non-slip TPE VDE sleeve
- made from shockproof, heat- and cold-resistant, not readily flammable, cadmium-free TPE (thermoplastic elastomer)
- elastic grip zone and hard core
- polished surface
- nickel-chromium electrogalvanised coating protects against corrosion

### KSE 160 – KSE 200 – SE TOP

Professional side-cutting pliers for piano wire



### SE HD 140 – SE HD 160 – SE HD 180

Side-cutting pliers for hard wire



#### Side-cutting pliers to DIN ISO 5749

- cutting edges additionally induction-hardened to approx. 64 HRC

- for cutting soft and piano wire

#### KSE 160 - KSE 200

- optimised force transmission
- precision cutting edges

#### SE TOP

- with lap joint
- especially fine precision cutting edges

#### Side-cutting pliers DIN ISO 5749

- with lap joint
- with precision cutting edges
- cutting edges additionally inductively hardened to approx. 62 HRC
- special tool steel

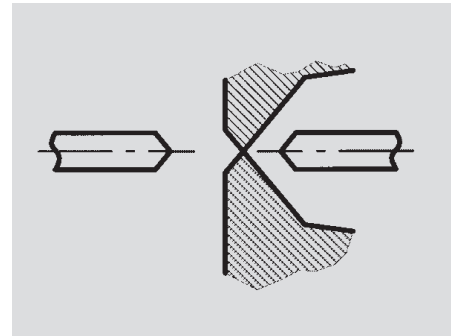
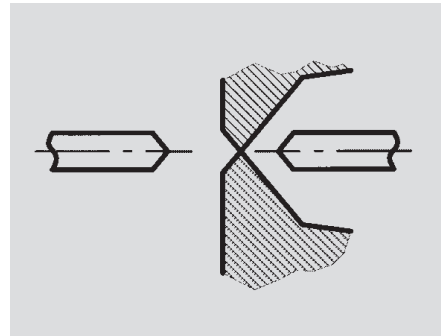

### Technical data

Stripping	
Stripping diameter, max.	mm
Conductor cross-section, max.	mm <sup>2</sup>
Cutting performance	
Conductor diameter max. (H)	mm
Conductor diameter max. (MH)	mm
Conductor diameter max. (P)	mm
Tool data	
Cutter hardness	HRC
Total length tools	mm
Weight	g
Information	

	KSE 160	KSE 200	SE TOP
Stripping diameter, max.			
Conductor cross-section, max.			
Conductor diameter max. (H)	2.5	3	2.5
Conductor diameter max. (MH)	3.5	4.2	3.5
Conductor diameter max. (P)	2	2.5	2
Cutter hardness	64	64	64
Total length tools	160	200	160
Weight	243	325	251
<b>(MH)</b> medium-hard wire; <b>(H)</b> hard wire; <b>(P)</b> piano wire			

	SE HD 140	SE HD 160	SE HD 180
Stripping diameter, max.			
Conductor cross-section, max.			
Conductor diameter max. (H)	2	2.3	3
Conductor diameter max. (MH)	2.8	3	3.8
Conductor diameter max. (P)	1.4	1.6	1.8
Cutter hardness	62	62	62
Total length tools	140	160	180
Weight	203	253	291
<b>(MH)</b> medium-hard wire; <b>(H)</b> hard wire; <b>(P)</b> piano wire			

### Ordering data

Version
Information

Type	Qty.	Order No.
KSE 160	1	9046410000
KSE 200	1	9046420000
SE TOP	1	9046340000
Information		

Type	Qty.	Order No.
SE HD 140	1	9046310000
SE HD 160	1	9046320000
SE HD 180	1	9046330000
Information		

### Accessories

Information

Information

Information

**VDE insulated telephone pliers**

up to 1000 V (AC) and 1500 V (DC) protective insulation to IEC 900, DIN EN 60900

- drop-forged from high-quality special tool steels
- safety handle with ergonomic and non-slip TPE VDE sleeve
- made from shockproof, heat-and cold-resistant, not readily flammable, cadmium-free TPE (thermoplastic elastomer)
- elastic grip zone and hard core
- polished surface
- nickel-chromium electrogalvanised coating protects against corrosion

**FRZ SG 160 – FRZ SG 200**

Bent half-round-nose pliers with cutter (telephone pliers)



**FRZ S 160 – FRZ S 200**

Half-round-nose pliers with cutter (telephone pliers)



Bent telephone pliers with cutter to DIN ISO 5745

- half-round jaws
- serrated gripping surfaces
- tip bent through 45°
- cutting edges additionally inductively hardened to approx. 60 HRC
- special tool steel

Telephone pliers with cutter to DIN ISO 5745

- half-round jaws
- serrated gripping surfaces
- cutting edges additionally inductively hardened to approx. 60 HRC
- special tool steel

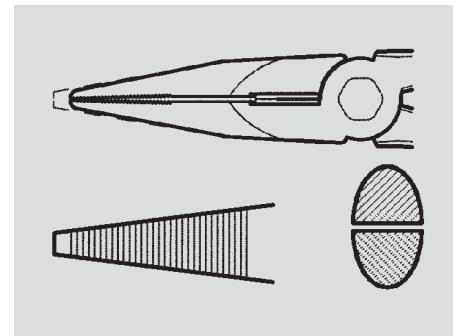
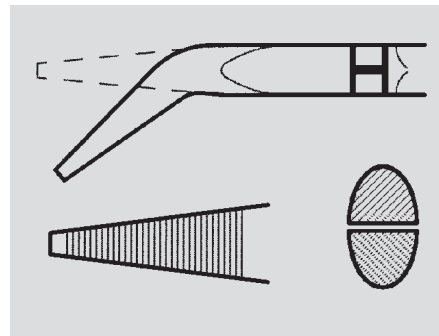

**Technical data**

Stripping	
Stripping diameter, max.	mm
Conductor cross-section, max.	mm <sup>2</sup>
Cutting performance	
Conductor diameter max. (H)	mm
Conductor diameter max. (MH)	mm
Conductor diameter max. (P)	mm
Tool data	
Cutter hardness	HRC
Total length tools	mm
Weight	g
Information	

FRZ SG 160	FRZ SG 200
1.6	1.8
2.5	2.8
60	60
160	200
162	207
(MH) medium-hard wire; (H) hard wire; (P) piano wire	

FRZ S 160	FRZ S 200
1.6	1.8
2.5	2.8
60	60
160	200
170	224
(MH) medium-hard wire; (H) hard wire; (P) piano wire	

**Ordering data**

Version
Information

Type	Qty.	Order No.
FRZ SG 160	1	9046390000
FRZ SG 200	1	9046400000
Information		

Type	Qty.	Order No.
FRZ S 160	1	9046370000
FRZ S 200	1	9046380000
Information		

**Accessories**

Information

Information

Information



**VDE insulated special function pliers**

**up to 1000 V (AC) and 1500 V (DC) protective insulation to IEC 900, DIN EN 60900**

- drop-forged from high-quality special tool steels
- safety handle with ergonomic and non-slip TPE VDE sleeve
- made from shockproof, heat-and cold-resistant, not readily flammable, cadmium-free TPE (thermoplastic elastomer)
- elastic grip zone and hard core
- polished surface
- nickel-chromium electrogalvanised coating protects against corrosion

**VZZ S**

**Multipurpose pliers**



**Bent half-round-nose pliers with cutter to DIN ISO 5745**

- for gripping, guiding, stripping, crimping and many other tasks
- serrated gripping surfaces
- tip bent through 35°
- cutting edges inductively hardened to approx. 60 HRC

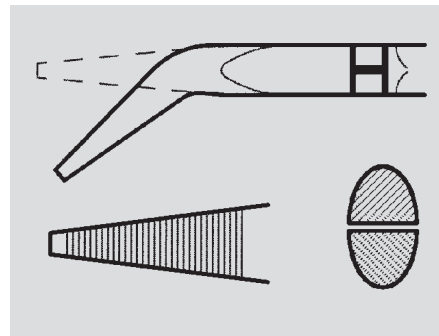

**AIZ 160**

**Wire stripper**



**Wire stripper to DIN ISO 5744**

- for stripping cables and wires up to 5 mm O.D.
- forged in die
- high-quality finish due to induction hardening
- adjusting screw and locknut for setting appropriate conductor diameter
- opening spring for convenient working
- special tool steel

**Technical data**

Stripping	
Stripping diameter, max.	mm
Conductor cross-section, max.	mm <sup>2</sup>
Cutting performance	
Conductor diameter max. (H)	mm
Conductor diameter max. (MH)	mm
Conductor diameter max. (P)	mm
Tool data	
Cutter hardness	HRC
Total length tools	mm
Weight	g
Information	

VZZ S		
	1.6	
	2.5	
	60	
	160	
	175	
(MH) medium-hard wire; (H) hard wire; (P) piano wire		

AIZ 160		
	5	
	10	
	160	
	193	

**Ordering data**

Version
Information

Type	Qty.	Order No.
VZZ S	1	9046470000
Information		

Type	Qty.	Order No.
AIZ 160	1	9046440000
Information		

**Accessories**

Information

Information

Information

